

HONDA

GX Series Engines





GENUINE HONDA



There are many reasons to insist on genuine Honda engines. As the world’s largest engine manufacturer, Honda offers more engine experience than anyone. Experience born on racetracks and roadways around the globe. Experience that keeps us on the cutting edge of engine performance technology and crosses our entire product line. From automobiles, race cars, motorcycles and all-terrain vehicles to marine engines, power equipment products and general-purpose engines, Honda is committed to designing products that meet or exceed the demands of our customers across the board. Based on the wide variety of products offered with our Honda engines, we’re experts at matching the right engine for the right job and producing engines that will “get the job done”.



Throughout our history, Honda has been dedicated to technological and environmental innovation, and today is no different. After all, we have a legendary reputation to live up to. A reputation for unsurpassed quality, performance and reliability. A reputation worth considering the next time you’re in the market for an engine.



Net Power

The SAE J1349 standard measures net horsepower with the manufacturer’s production muffler and air cleaner in place. Net horsepower more closely correlates with the power the operator will experience when using a Honda engine powered product. The power rating of the engines indicated in this document is the net power output tested on a production engine for the model noted and measured at the rpm specified. Mass production engines may vary from this value. Actual power output for the engine installed in the final machine will vary depending on numerous factors, including the operation speed of the engine in application, environmental conditions, maintenance and other variables.

Pictured counter-clockwise from above: Honda Fit EV Concept Vehicle, Honda CBR1000RR, Honda Advanced Robotics – Asimo, MCHP (Micro-sized Combined Heat and Power System), Honda Aquatrax, Honda BF250 outboard, Honda Jet

The GX Series Engines have reliability written all over them.

Honda GX Series Engines have long been recognized as the industry leader in providing reliable, easy-starting and fuel efficient small engines. You'll find Honda GX Series overhead valve engines on a wide variety of construction, maintenance and premium power equipment. The rental industry, where power equipment is subjected to the ultimate test of durability, relies heavily on Honda OHV engines to ensure customer satisfaction and a minimal level of maintenance and repair. When it comes to reliability, trust the engines with the Honda name.

GX Series Engines — The Next Generation.

(Models GX120 — GX390)

Less Noise

The operator will enjoy noise reduction levels ranging from 2.5 to 8db thanks to Honda's redesigned air cleaner and muffler. Vibration levels have also been reduced through the use of an all new, light weight piston.

Same "Footprint"

OEMs can pass along new improvements and features without having to worry about costly and time consuming product modifications. New GX Series models have the exact footprint and fit into the same envelope as their similarly sized predecessors.

EPA Phase 3 Ready!

Once again, Honda leads the way in offering power solutions that meet EPA Phase 3 emission regulations. Even more importantly, Honda GX engines meet these regulations without the need for a catalyst.



Honda GX Series Engines carry a 3-Year Warranty.* You always knew they were worry free, but now we've put it in writing.

*Warranty applies to all Honda GX Series Engines, 100cc or larger purchased at retail or put into rental service since January 1st, 2009. Warranty excludes the Honda GXV160 model. See full warranty details at Honda.com.



Quality and performance are standard with Honda GX Series engines.

From cast iron cylinder sleeves to Automatic Decompression, Honda offers a variety of power solutions to meet your specific application. Choose from over 130 standard single cylinder engine variations. A variety of features are available, depending on the specific model and application, including four types of air filtration systems and Oil Alert® which warns the user before oil reaches an unsafe operating level. Other options include 2-to-1 and 6-to-1 reduction units, one to 18 amp charging, lamp coils and shaft variations to suit every standard application. For the most current information on Honda engine technologies, visit our website at engines.honda.com.

Environmental responsibility has been an integral part of our product development philosophy years before emission levels were established. In fact, with minor modifications, the GX Series engine design introduced in 1983 continues to meet today's EPA and CARB emission level standards. Honda's advanced engine technology offers a number of distinct advantages including fuel savings, lower emissions and standardized replacement parts readily available through one of over 14,000 local Honda engine dealers, nationwide. For the most current information on Honda engine distributors and dealers, visit our website at engines.honda.com.

Prove it to yourself.

Next time you visit a rental center, see a landscape truck or pass by a construction site, you'll probably see a Honda GX engine-powered piece of equipment. Stop and ask them what they think of the Honda engine. Chances are they'll tell you they wouldn't use anything else. Sure, you can find a less expensive engine, but you won't find a more reliable one.

Horizontal Shaft

GX100



Engine Type	Air-cooled, 4-Stroke, OHC, single cylinder
Bore x Stroke	2.2" x 1.6" (56 x 40 mm)
Displacement	6.0 cu in (98 cm ³)
Compression Ratio	8.5 : 1
Net Power (kW/rpm)*	2.8hp (2.1kW) at 3,600 rpm
Net Torque*	4.2 lbs ft (5.7 Nm) at 3,600 rpm
PTO Shaft Rotation	Counterclockwise (from PTO shaft side)
Ignition System	Transistorized Magneto
Starting System	Recoil Starter
Carburetor	Horizontal type butterfly valve
Lubrication System	Forced Splash
Governor System	Centrifugal Mechanical
Air Cleaner	Dual Element Type
Oil Capacity	0.42 US qt (0.40l)
Fuel Tank Capacity (liter)	0.81 US qt (0.77l)
Dimensions (L x W x H)	11.6" (295mm) x 12.0" (304mm) x 15.8" (402mm)
Dry Weight	23.4 lbs (10.6 kg)

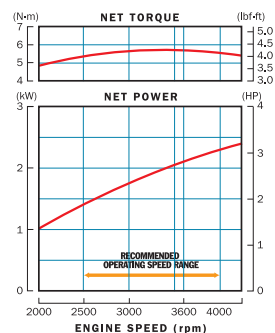

GX120



Engine Type	Air-cooled, 4-Stroke, OHV, single cylinder
Bore x Stroke	2.4" x 1.7" (60 x 42 mm)
Displacement	7.2 cu in (118 cm ³)
Compression Ratio	8.5 : 1
Net Power (kW/rpm)*	3.5 hp (2.6 kW) at 3,600 rpm
Net Torque*	5.4 lbs ft (7.3 Nm) at 2,500 rpm
PTO Shaft Rotation	Counterclockwise (from PTO shaft side)
Ignition System	Transistor Magneto
Starting System	Recoil Starter
Carburetor	Butterfly
Lubrication System	Splash
Governor System	Mechanical
Air Cleaner	Dual Element
Oil Capacity	0.59 US qt (0.56 L)
Fuel Tank Capacity (liter)	2.1 US qt (2.0 L)
Evaporative Emissions	Low permeation hose and purge joint provided
Exhaust Emissions	Certified for use in all 50 states
Dimensions (L x W x H) Q-Shaft	11.7" (297 mm) x 13.6" (346 mm) x 13.0" (329 mm)
Dry Weight	29 lbs (13.0 kg)

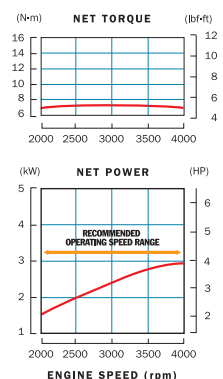

GX160



Engine Type	Air-cooled, 4-Stroke, OHV, single cylinder
Bore x Stroke	2.7" x 1.8" (68 x 45 mm)
Displacement	9.9 cu in (163 cm ³)
Compression Ratio	9.0 : 1
Net Power (kW/rpm)*	4.8 hp (3.6 kW) at 3,600 rpm
Net Torque*	7.6 lbs ft (10.3 Nm) at 2,500 rpm
PTO Shaft Rotation	Counterclockwise (from PTO shaft side)
Ignition System	Transistor Magneto
Starting System	Recoil & Electric Starter
Carburetor	Butterfly
Lubrication System	Splash
Governor System	Mechanical
Air Cleaner	Dual Element
Oil Capacity	0.61 US qt (0.58 L)
Fuel Tank Capacity (liter)	3.3 US qt (3.1 L)
Evaporative Emissions	Low permeation hose and purge joint provided
Exhaust Emissions	Certified for use in all 50 states
Dimensions (L x W x H) Q-Shaft	12.2" (312 mm) x 14.3" (362 mm) x 13.6" (346 mm)
Dry Weight	33 lbs (15.1 kg)

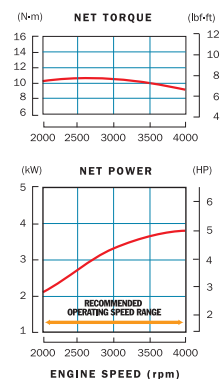

GX200



Engine Type	Air-cooled, 4-Stroke, OHV, single cylinder
Bore x Stroke	2.7" x 2.1" (68 x 54 mm)
Displacement	12 cu in (196 cm ³)
Compression Ratio	8.5 : 1
Net Power (kW/rpm)*	5.5 hp (4.1 kW) at 3,600 rpm
Net Torque*	9.1 lbs ft (12.4 Nm) at 2,500 rpm
PTO Shaft Rotation	Counterclockwise (from PTO shaft side)
Ignition System	Transistor Magneto
Starting System	Recoil & Electric Starter
Carburetor	Butterfly
Lubrication System	Splash
Governor System	Mechanical
Air Cleaner	Dual Element
Oil Capacity	0.63 US qt (0.60 L)
Fuel Tank Capacity (liter)	3.3 US qt (3.1 L)
Evaporative Emissions	Low permeation hose and purge joint provided
Exhaust Emissions	Certified for use in all 50 states
Dimensions (L x W x H) Q-Shaft	12.6" (321 mm) x 14.8" (376 mm) x 13.6" (346 mm)
Dry Weight	35 lbs (16.1 kg)

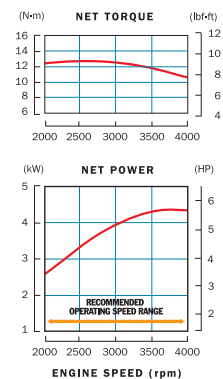

* The power rating of the engines indicated in this document measures the net power output at 3600 rpm (7000 rpm for model GXH50, GXV50, GX25 and GX35) and net torque at 2500 rpm, as tested on a production engine. Mass production engines may vary from this value. Actual power output for the engine installed in the final machine will vary depending

Horizontal Shaft

GX240



Engine Type	Air-cooled, 4-Stroke, OHV, single cylinder
Bore x Stroke	3.0" x 2.3" (77 x 58 mm)
Displacement	16 cu in (270 cm ³)
Compression Ratio	8.5 : 1
Net Power (kW/rpm)*	7.9 hp (5.9 kW) at 3,600 rpm
Net Torque*	13.5 lbs ft (18.3 Nm) at 2,500 rpm
PTO Shaft Rotation	Counterclockwise (from PTO shaft side)
Ignition System	Digital CDI with variable ignition timing
Starting System	Recoil & Electric Starter
Carburetor	Butterfly
Lubrication System	Splash
Governor System	Centrifugal Mass Type
Air Cleaner	Dual Element
Oil Capacity	1.16 US qt (1.1 L)
Fuel Tank Capacity (liter)	6.4 US qt (6.1 L)
Evaporative Emissions	Low permeation hose and purge joint provided
Exhaust Emissions	Certified for use in all 50 states
Dimensions (L x W x H) Q-Shaft	15.0" (380 mm) x 16.9" (429 mm) x 16.6" (422 mm)
Dry Weight	55 lbs (25.0 kg)

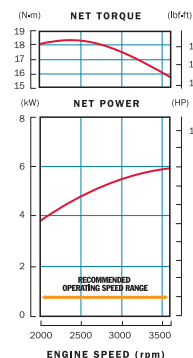

GX270



Engine Type	Air-cooled, 4-Stroke, OHV, single cylinder
Bore x Stroke	3.0" x 2.3" (77 x 58 mm)
Displacement	16 cu in (270 cm ³)
Compression Ratio	8.5 : 1
Net Power (kW/rpm)*	8.5 hp (6.3 kW) at 3,600 rpm
Net Torque*	14.1 lbs ft (19.1 Nm) at 2,500 rpm
PTO Shaft Rotation	Counterclockwise (from PTO shaft side)
Ignition System	Digital CDI with variable ignition timing
Starting System	Recoil & Electric Starter
Carburetor	Butterfly
Lubrication System	Splash
Governor System	Centrifugal Mass Type
Air Cleaner	Dual Element
Oil Capacity	1.16 US qt (1.1 L)
Fuel Tank Capacity (liter)	6.4 US qt (6.1 L)
Evaporative Emissions	Low permeation hose and purge joint provided
Exhaust Emissions	Certified for use in all 50 states
Dimensions (L x W x H) Q-Shaft	15.0" (380 mm) x 16.9" (429 mm) x 16.6" (422 mm)
Dry Weight	55 lbs (25.0 kg)

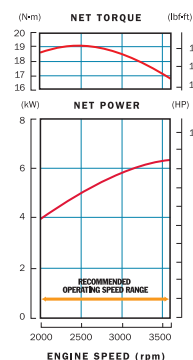

GX340



Engine Type	Air-cooled, 4-Stroke, OHV, single cylinder
Bore x Stroke	3.5" x 2.5" (88 x 64 mm)
Displacement	24 cu in (389 cm ³)
Compression Ratio	8.2 : 1
Net Power (kW/rpm)*	10.7 hp (8.0 kW) at 3,600 rpm
Net Torque*	19.5 lbs ft (26.4 Nm) at 2,500 rpm
PTO Shaft Rotation	Counterclockwise (from PTO shaft side)
Ignition System	Digital CDI with variable ignition timing
Starting System	Recoil & Electric Starter
Carburetor	Butterfly
Lubrication System	Splash
Governor System	Centrifugal Mass Type
Air Cleaner	Dual Element
Oil Capacity	1.16 US qt (1.1 L)
Fuel Tank Capacity (liter)	6.4 US qt (6.1 L)
Evaporative Emissions	Low permeation hose and purge joint provided
Exhaust Emissions	Certified for use in all 50 states
Dimensions (L x W x H) Q-Shaft	16.0" (407 mm) x 19.1" (485 mm) x 17.7" (449 mm)
Dry Weight	69 lbs (31.5 kg)

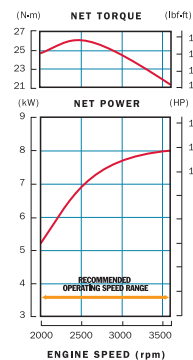

GX390



Engine Type	Air-cooled, 4-Stroke, OHV, single cylinder
Bore x Stroke	3.5" x 2.5" (88 x 64 mm)
Displacement	24 cu in (389 cm ³)
Compression Ratio	8.2 : 1
Net Power (kW/rpm)*	11.7 hp (8.7 kW) at 3,600 rpm
Net Torque*	19.5 lbs ft (26.4 s) at 2,500 rpm
PTO Shaft Rotation	Counterclockwise (from PTO shaft side)
Ignition System	Digital CDI with variable ignition timing
Starting System	Recoil & Electric Starter
Carburetor	Butterfly
Lubrication System	Splash
Governor System	Centrifugal Mass Type
Air Cleaner	Dual Element
Oil Capacity	1.16 US qt (1.1 L)
Fuel Tank Capacity (liter)	6.4 US qt (6.1 L)
Evaporative Emissions	Low permeation hose and purge joint provided
Exhaust Emissions	Certified for use in all 50 states
Dimensions (L x W x H) Q-Shaft	16.0" (407 mm) x 19.1" (485 mm) x 17.7" (449 mm)
Dry Weight	69 lbs (31.5 kg)

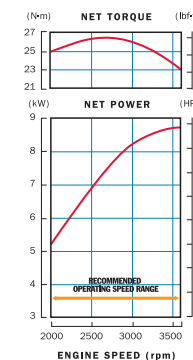

Horizontal Shaft cont.

GXH50



Engine Type	Air-cooled, 4-Stroke, OHV, single cylinder
Bore x Stroke	1.65" x 1.42" (41.8 x 36 mm)
Displacement	2.99 cu in (49 cm ³)
Compression Ratio	8.0 : 1
Net Power (kW/rpm)*	2.1 hp (1.6kW) at 7,000 rpm
Net Torque*	2.0 lbs ft (2.7 Nm) at 4,500 rpm
PTO Shaft Rotation	Counterclockwise (from PTO shaft side)
Ignition System	Transistorized Magneto
Starting System	Recoil Starter
Carburetor	Float Type
Lubrication System	Forced Splash
Governor System	Centrifugal Mechanical
Air Cleaner	Semi-dry Type
Oil Capacity	0.26 US qt (0.25l)
Fuel Tank Capacity (liter)	0.81 US qt (0.77l)
Dimensions (L x W x H)	8.9" (225mm) x 10.8" (274mm) x 13.0" (353mm)
Dry Weight	12.1 lbs (5.5 kg)

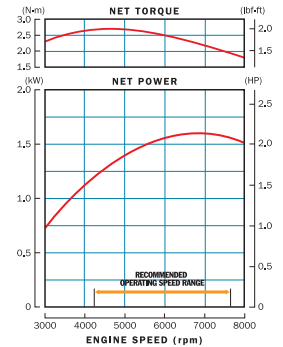

PTO Shaft Variations HORIZONTAL GX SERIES

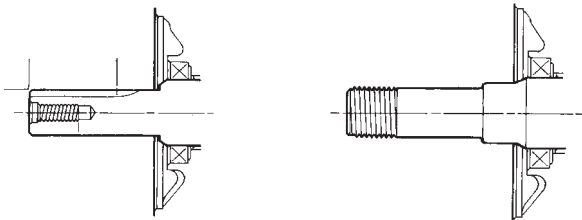

Q-TYPE SHAFT-FLAT KEY FOR GENERAL PURPOSE

P-TYPE AND T-TYPE THREADED CRANKSHAFT

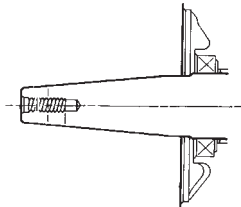

V-TYPE/TAPER

The Big GX, Now Even More Powerful.

(Models GX240 – GX390)

The new Honda GX Series (GX240-GX390) engines offer up to 6% more power over the original models.

The increase in power is achieved through several innovative improvements. First, the new GX series now employs a digital CDI ignition system to dramatically improve ignition timing. Second, the compression ratio has been increased and finally, combustion air flow has been enhanced through a more efficient air cleaner design that reduces air flow restriction.



Digital CDI Ignition Coil

Air Filtration Systems

Honda offers a variety of air filters to match your application, including dual-element, semi-dry, oil-bath and Cyclone Air Cleaner with inner-vent carburetor. "Inner-vent" carburetors are now available on specific models with dual-element filters.

Honda's inner-vent carburetor places the float bowl vent on the "clean side" of the air filter elements so that the air/fuel ratio remains more constant as the elements become dirty. This allows the length of the service interval for air filter maintenance to be more than doubled.

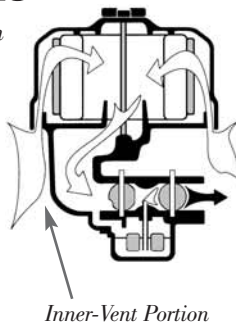

Inner-Vent Portion

Reduction Units

The 2-to-1 reduction unit is chain or gear driven and may include an automatic, centrifugally operated clutch.

Clutch engagement occurs at 1800 rpm and clutch lock occurs at 2200.

The 6-to-1 gear reduction is gear driven and does not include a clutch.

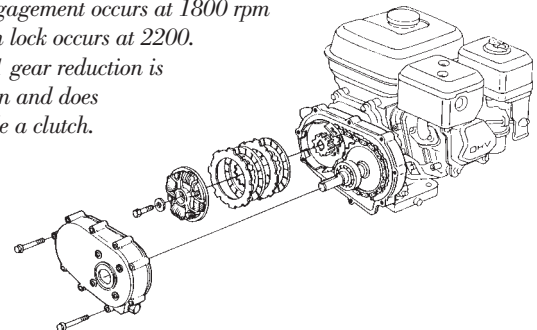

* The power rating of the engines indicated in this document measures the net power output at 3600 rpm (7000 rpm for model GXH50, GXV50, GX25 and GX35) and net torque at 2500 rpm, as tested on a production engine. Mass production engines may vary from this value. Actual power output for the engine installed in the final machine will vary depending

Vertical Shaft

GXV50



Engine Type	Air-cooled, 4-Stroke, OHV, single cylinder
Bore x Stroke	1.65" x 1.42" (41.8 x 36 mm)
Displacement	2.99 cu in (49 cm ³)
Compression Ratio	8.0 : 1
Net Power (kW/rpm)*	2.1hp (1.6kW) at 7,000 rpm
Net Torque*	2.0 lbs ft (2.7 Nm) at 4,500 rpm
PTO Shaft Rotation	Counterclockwise (from PTO shaft side)
Ignition System	Transistorized Magneto
Starting System	Recoil Starter
Carburetor	Float Type
Lubrication System	Forced Splash
Governor System	Centrifugal Mechanical
Air Cleaner	Semi-dry Type
Oil Capacity	0.26 US qt (0.25l)
Fuel Tank Capacity (liter)	0.29 US qt (0.27l)
Dimensions (L x W x H)	9.8" (249mm) x 11.3" (286mm) x 7.8" (198mm)
Dry Weight	11.5 lbs (5.2 kg)

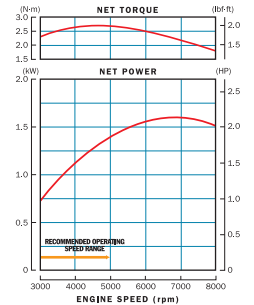

GXV160



Engine Type	Air-cooled 4-stroke OHV single cylinder
Bore x Stroke	2.7" x 1.8" (68 x 45 mm)
Displacement	10 cu in (163 cm ³)
Compression Ratio	8.0 : 1
Net Power (kW/rpm)*	4.3hp (3.2kW) at 3,600 rpm
Net Torque*	7.1 lbs ft (9.6 Nm) at 2,500 rpm
PTO Shaft Rotation	Counterclockwise (from PTO shaft side)
Ignition System	Transistorized Magneto
Starting System	Recoil Starter
Carburetor	Horizontal type butterfly valve
Lubrication System	Forced Splash
Governor System	Centrifugal Mechanical
Air Cleaner	Dual Element
Oil Capacity	0.69 US qt (0.65l)
Fuel Tank Capacity (liter)	1.9 US qt (1.8l)
Dimensions (L x W x H)	16.3" (415mm) x 14.1" (359mm) x 13.9" (354mm)
Dry Weight	31.5 lbs (14.3 kg)

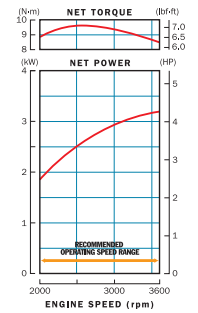

GXV340



Engine Type	Air-cooled 4-stroke OHV single cylinder
Bore x Stroke	3.2" x 2.5" (82 x 64 mm)
Displacement	20.6 cu in (337 cm ³)
Compression Ratio	7.7 : 1
Net Power (kW/rpm)*	8.9hp (6.6kW) at 3,600 rpm
Net Torque*	15.9 lbs ft (21.6 Nm) at 2,500 rpm
PTO Shaft Rotation	Counterclockwise (from PTO shaft side)
Ignition System	Transistorized Magneto
Starting System	Recoil and Electric Starter
Carburetor	Horizontal type butterfly valve
Lubrication System	Pressure and Splash
Governor System	Centrifugal Mechanical
Air Cleaner	Dual Element
Oil Capacity	1.2 US qt (1.1l)
Fuel Tank Capacity (liter)	2.2 US qt (2.1l)
Dimensions (L x W x H)	17.0" (433mm) x 15.0" (382mm) x 15.9" (406mm)
Dry Weight	71.2 lbs (32.3 kg)

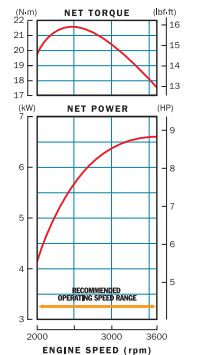

GXV390



Engine Type	Air-cooled, 4-Stroke, OHV, single cylinder
Bore x Stroke	3.5" x 2.5" (88 x 64 mm)
Displacement	23.7 cu in (389 cm ³)
Compression Ratio	7.7 : 1
Net Power (kW/rpm)*	10.2hp (7.6kW) at 3,600 rpm
Net Torque*	17.8 lbs ft (24.2 Nm) at 2,500 rpm
PTO Shaft Rotation	Counterclockwise (from PTO shaft side)
Ignition System	Transistorized Magneto
Starting System	Recoil and Electric Starter
Carburetor	Horizontal type butterfly valve
Lubrication System	Pressure and Splash
Governor System	Centrifugal Mechanical
Air Cleaner	Dual Element
Oil Capacity	1.2 US qt (1.1l)
Fuel Tank Capacity (liter)	2.2 US qt (2.1l)
Dimensions (L x W x H)	17.0" (433mm) x 15.0" (382mm) x 15.9" (406mm)
Dry Weight	73.3 lbs (33.3 kg)

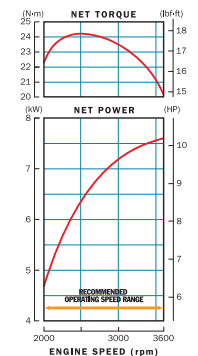

HONDA ENGINE DISTRIBUTORS

ALABAMA

R.W. DISTRIBUTORS, INC.
SEE MISSISSIPPI

ALASKA

SCOTSCO, INC
SEE OREGON

ARIZONA

TRU-POWER, INC.
SEE SOUTHERN CALIFORNIA

ARKANSAS

R.W. DISTRIBUTORS, INC.
SEE MISSISSIPPI

CALIFORNIA

Northern California
PACE WEST, INC.
www.pacelink.com
5850 Adler Circle
Sacramento, CA 95828
(734) 453-6258
FAX (916) 383-6550
BruceT@pacelink.com

Southern California

TRU-POWER, INC.
www.trupower.com
22520-A Temescal Canyon Rd.
Corona, CA 92883
(951) 277-3180
FAX (951) 277-3190
sales@trupower.com

COLORADO

E. C. POWER SYSTEMS
www.ecpower.com
3233 Oakland Street
Aurora, CO 80010
(303) 360-7110
FAX (303) 360-7519
rickri@e-c-co.com

CONNECTICUT

TIDEWATER
SEE VIRGINIA

DELAWARE

TIDEWATER
SEE VIRGINIA

DISTRICT OF COLUMBIA

TIDEWATER
SEE VIRGINIA

FLORIDA

ROBERTS SUPPLY, INC.
www.robertssupply.com
4203 Metric Drive
Winter Park, FL 32792
(407) 657-5555
FAX (407) 657-4007
info@robertssupply.com

GEORGIA

M.T.A. DISTRIBUTORS
SEE TENNESSEE

HAWAII

SCOTSCO, INC.
SEE OREGON

IDAHO

E. C. POWER SYSTEMS
www.ecpower.com
4499 Market Street
Boise, ID 83705
(208) 342-6541
FAX (208) 345-4308
wintons@e-c-co.com

ILLINOIS

POWER EQUIPMENT CO.
www.peco1948.com
211 W Stephanie Drive
Cortland, IL 60112
(815) 754-4090
FAX (815) 754-4280
sales@peco1948.com

INDIANA

POWER EQUIPMENT CO.
SEE ILLINOIS

IOWA

IOWA POWER PRODUCTS
www.iowapower.com
522 Brooks Road
Iowa Falls, IA 50126
(641) 648-2507
FAX (641) 648-5013
iowapower@iowapower.com

KANSAS

KANSAS CITY POWER PROD.
www.kcpp.com
80 S. James Street
Kansas City, KS 66118
(913) 321-7040
FAX (913) 321-7341
info@kcpp.com

KENTUCKY

M.T.A. DISTRIBUTORS
SEE TENNESSEE

Northern Kentucky-Cincinnati area

HAYWARD DISTRIBUTING
SEE OHIO

LOUISIANA

R.W. DISTRIBUTORS, INC.
SEE MISSISSIPPI

MAINE

EASTERN EQUIPMENT, INC.
SEE NEW HAMPSHIRE

MARYLAND

TIDEWATER
SEE VIRGINIA

MASSACHUSETTS

EASTERN EQUIPMENT, INC.
SEE NEW HAMPSHIRE

MICHIGAN

PACE, INC.
www.pacelink.com
739 South Mill Street
Plymouth, MI 48170
(734) 453-6258
FAX (734) 453-5320
pace@pacelink.com

Northern Michigan

ENGINE POWER INC.
SEE WISCONSIN

MINNESOTA

GREAT NORTHERN EQUIP. DIST.
www.gnedi.com
20195 South Diamond Lake Road
Rogers, MN 55374
(763) 428-2237
FAX (763) 428-4821
chrisb@gnedi.com

MISSISSIPPI

R.W. DISTRIBUTORS, INC.
1046 Hwy 471
Brandon, MS 39042
(601) 939-0204
FAX (800) 748-9965
Mail Address
P.O. Box 1409
Brandon, MS 39043
general@rwdist.net

MISSOURI

KANSAS CITY POWER PRODUCTS
SEE KANSAS

MONTANA

E. C. POWER SYSTEMS
SEE IDAHO

NEBRASKA

Anderson Industrial Engines
www.ai-engines.com
5532 Center Street
Omaha, NE 68106
(402) 558-8700
FAX (402) 558-8249
info@ai-engines.com

NEVADA

PACE WEST INC.
SEE NORTHRN CALIFORNIA

TRU-POWER, INC.

SEE SOUTHERN CALIFORNIA

E. C. POWER SYSTEMS

SEE UTAH

NEW HAMPSHIRE

EASTERN EQUIPMENT, INC.
www.easternequipmentinc.com
6 "B" Street
Derry, NH 03038
(603) 437-0407
FAX (603) 437-0815
gmiscoeastern@aol.com

NEW JERSEY

TIDEWATER
SEE VIRGINIA

NEW MEXICO

LIGHTBOURN EQUIPMENT
SEE TEXAS (DALLAS)

NEW YORK

EASTERN EQUIPMENT, INC.
SEE NEW HAMPSHIRE

NORTH CAROLINA

TIDEWATER
SEE VIRGINIA

NORTH DAKOTA

GREAT NORTHERN EQUIPMENT
SEE MINNESOTA

OHIO

HAYWARD DISTRIBUTING
www.haydist.com
4061 Perimeter Drive
Columbus, OH 43228
(614) 272-5953
FAX (614) 272-5959
rstruthers@haydist.com

North Western Ohio

PACE INC.
SEE MICHIGAN

OKLAHOMA

SMITH DISTRIBUTING CO.
www.smithdistributingcompany.com
4110 N.W. 10th Street
Oklahoma City, OK 73107
(405) 947-6484
FAX (405) 946-1251
parts@smithdistributingcompany.com

OREGON

SCOTSCO, INC.
www.scotsco.com
16750 S.E. Kens Ct.
Milwaukie, OR 97267
(503) 653-7791
FAX (503) 653-7838
tfrandsen@scotsco.com

PENNSYLVANIA

PAUL B. MOYER & SONS, INC.
www.paulbmoyer.com
190 S. Clinton Street
Doylestown, PA 18901
(215) 348-1270
FAX (215) 348-7651
information@paulbmoyer.com

PUERTO RICO/VIRGIN ISLANDS

BELLA INTERNATIONAL
www.bellainternational.com
65 Infanteria, KM2.2
Rio Piedras, PR 00923
(787) 620-5838
FAX (787) 620-5829

RHODE ISLAND

EASTERN EQUIPMENT, INC
SEE NEW HAMPSHIRE

SOUTH CAROLINA

TIDEWATER
SEE VIRGINIA

SOUTH DAKOTA

GREAT NORTHERN EQUIPMENT
SEE MINNESOTA

TENNESSEE

M.T.A. DISTRIBUTORS
www.mtadistributors.com
555 Hickory Hills Blvd.
Whites Creek, TN 37189-9244
(615) 299-8777
FAX (615) 299-0464
customerservice@mtadistributors.com

TEXAS

LIGHTBOURN EQUIPMENT
www.lightbourneequipment.com
13649 Beta Road
Dallas, TX 75244
(972) 233-5151
FAX (972) 661-0738
dvh@lightbourneequipment.com

LIGHTBOURN EQUIPMENT

3615 Willowbend Blvd, Suite 408
Houston, TX 77054
(713) 741-2003
FAX (713) 741-1909
swk@lightbourneequipment.com

UTAH

E. C. POWER SYSTEMS
www.ecpower.com
3738 West 2340 S. Suite E
Salt Lake City, UT 84120
(800) 886-1424 (800) 462-3370
FAX (801) 886-1464
cheh@e-c-co.com

VERMONT

EASTERN EQUIPMENT, INC.
SEE NEW HAMPSHIRE

VIRGINIA

TIDEWATER POWER EQUIP. CO.
www.tpeco.com
5795 Thurston Ave
Virginia Beach, VA 23455
(757) 464-1755
FAX (800) 288-8953
info@tpeco.com

WASHINGTON

SCOTSCO, INC.
SEE OREGON

WEST VIRGINIA

HAYWARD DISTRIBUTING
SEE OHIO

TIDEWATER POWER EQUIP. CO.

SEE VIRGINIA

WISCONSIN

ENGINE POWER, INC.
www.enginepower.com
1830 Executive Drive
Oconomowoc, WI 53066-4831
(262) 567-8575
FAX (262) 567-2556
postoff@enginepower.com

WYOMING

E. C. POWER SYSTEMS
SEE COLORADO



GC SERIES



GS SERIES



GX SERIES



IGX SERIES



V-TWIN SERIES



MINI 4-STROKE SERIES

HONDA
ENGINES

Built like no other.

Visit us at engines.honda.com

For optimum performance and safety we recommend you read the owner's manual before operating your Honda Power Equipment. Specifications subject to change without notice.

All images contained herein are either owned by American Honda Motor Co., Inc., or used under a valid license. It is a violation of federal law to reproduce these images without express written permission from American Honda Motor Co., Inc., or the individual copyright owner of such images. All rights reserved. HONDA, the HONDA ENGINES logo, Honda engine model names and their trade dress are trademarks of Honda Motor Co., Ltd. used under license from American Honda Motor Co., Inc. Many Honda engine and vehicle model names, and associated trade dress may be seen at www.honda.com.

©2012 American Honda Motor Co., Inc. C0476